

MULTI-FLO

WASTEWATER TREATMENT SYSTEMS

PROCEDURES FOR ASSEMBLY AND INSTALLATION

**A Division of Consolidated Treatment Systems, Inc.
1501 Commerce Center Drive
Franklin, OH 45005
Tel: 937-746-2727
Fax: 937-746-1446
www.multi-flo.com**

MULTI-FLO TANK COMPONENTS

Fig. 1.1

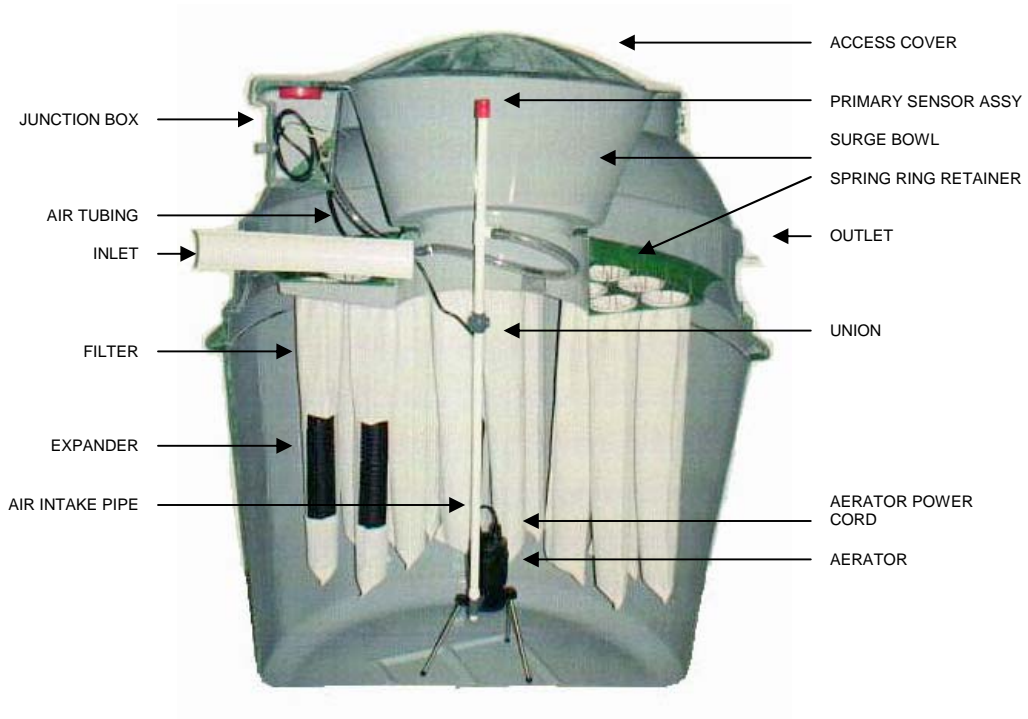

TYPICAL INSTALLATION (Cross Section)

Fig. 1.2

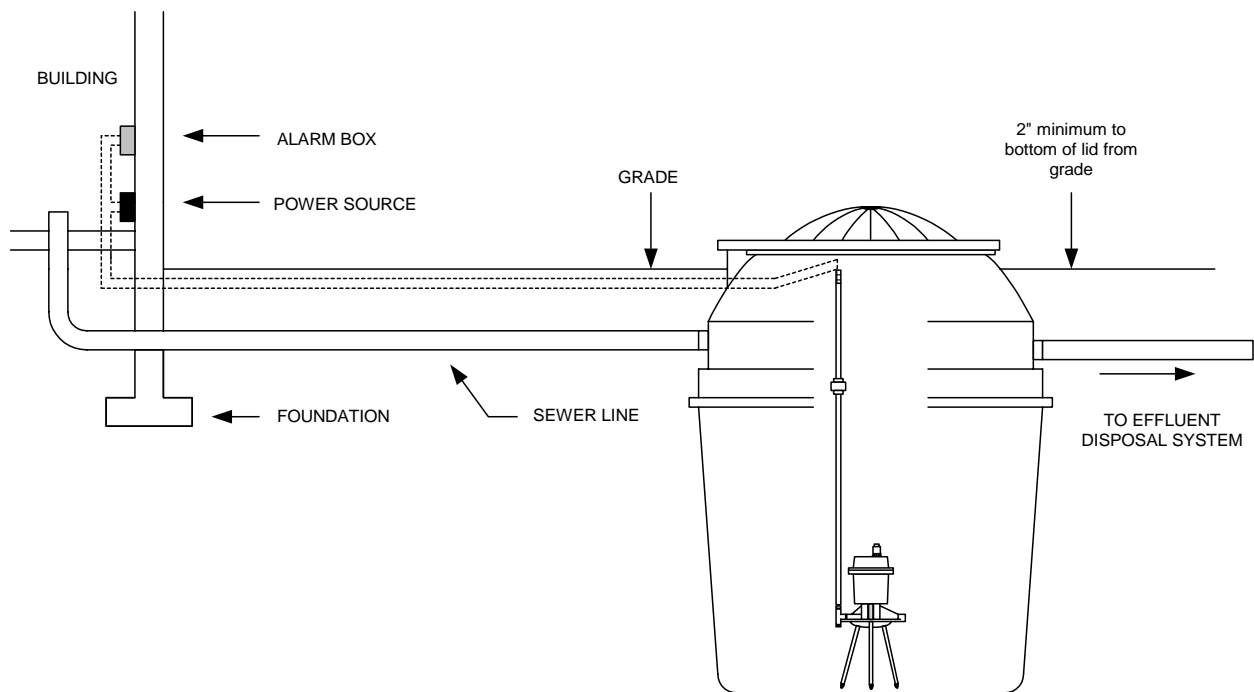

MULTI-FLO
Procedures for
Assembly and Installation

Unless otherwise noted, the instructions within this manual may be used for all models (FTB 0.5, FTB 0.6, FTB 0.75, FTB 1.0 and FTB 1.5) of the **MULTI-FLO** wastewater treatment unit.

The installation must comply with state and local regulations

SECTION 1.0 SITE PREPARATION

1.10 LOCATION

1.11 **An accurate, detailed site plan is essential for successful installation of *MULTI-FLO* units.** The site plan should show the locations and elevations of the wastewater treatment unit and effluent disposal system. Check to make sure the site plan accurately reflects the conditions actually existing at the site and that all required set-backs (i.e., to property lines, wells, etc.) are being met.

1.20 GRADE AND GROUND CONTOUR

1.21 Position the wastewater treatment unit in accordance with the plan. Confirm the accuracy of the elevations shown in the plan.

SURFACE WATER MUST NOT ENTER THE SYSTEM AROUND THE ACCESS COVER OR FROM THE DISCHARGE PIPE.

1.30 COVER EXPOSURE

1.31 The access cover must be exposed at all times to permit the system to function properly and to allow for routine maintenance. There should be a minimum of two (2) inches between the bottom of the lid and the finished grade (refer to Fig. 1.2).

1.40 BUILDING SEWER LINE

1.41 Make sure that the sewer pipe from the building has the proper slope to meet the inlet invert of the **MULTI-FLO** and maintain the grade requirements for the exposure of the cover.

1.50 EXCAVATION PREPARATION

1.51 Mark off an area at least one foot larger than the dimensions of the **MULTI-FLO** and maintain the grade requirements for the exposure of the cover.

1.60 EXCAVATION (refer to Fig. 1.3)

1.61 Prepare the excavation. The opening should follow the area laid out in Section 1.51. Determine the required depth of the excavation based upon the elevation of the invert of the inlet sewer line (B) or the elevation of the finished grade (D), both of which should conform with the site plan. These dimensions are given for each model in Figure 1.3. NOTE: If the distance from the finish grade elevation to the bottom of the excavation exceeds the dimension (D) shown in Figure 1.3, a riser will be required (refer to Section 2.40). If digging in soil containing large rocks or clods of dirt, it may be necessary to remove an extra 6" to allow for bedding material (refer to Item 1.63).

MULTI-FLO TANK DIMENSIONS

Fig. 1.3

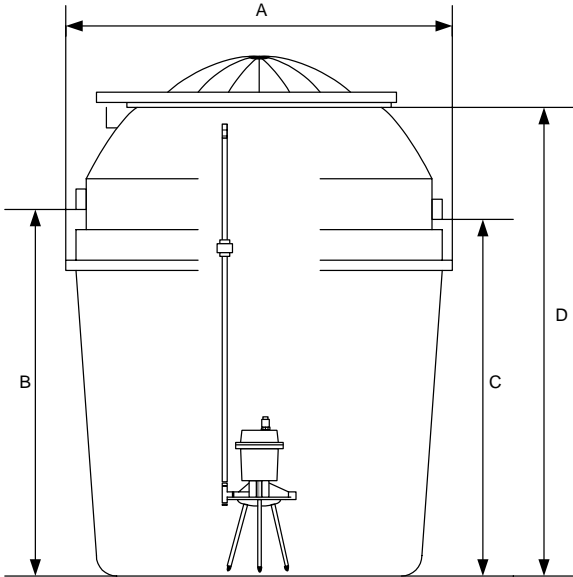

MODEL NUMBERS	DIMENSIONS			
	A	B	C	D
FTB 0.5	63	58	56	76
FTB 0.6	71	58	56	75
FTB 0.75	71	65	63	79
FTB 1.0	78	65	63	83
FTB 1.5	135 x 63	58	56	76

- A = OUTSIDE DIAMETER
- B = INLET INVERT FROM BOTTOM OF EXCAVATION
- C = OUTLET INVERT FROM BOTTOM OF EXCAVATION
- D = FINAL GRADE FROM BOTTOM OF EXCAVATION

1.62 Level the floor of the excavation.

1.63 If bedding material is required, place at least six inches of sand, pea gravel or other similar, suitable granular material on the bottom and smooth out evenly. If ground water is present, use pea gravel or class 2 river rock to build a base for the system. In all cases, the bottom should be level and well compacted. **Note: Localized soil and groundwater conditions may require specialized procedures to assure proper installation.**

SECTION 2.0 INSTALLATION OF THE TANK

2.10 PLACING THE WASTEWATER TREATMENT UNIT INTO THE EXCAVATION
(Refer to Fig. 2.1)

2.11 Rig the tank to lift. See unit specifications for actual weights. Except for the FTB 1.5, ropes can be attached to the inlet and outlet. Note: The FTB 1.5 has lifting hooks that must be used.

2.12 Slowly lower the tank into the hole, setting it carefully on the bottom.

2.13 Position the unit, so that the inlet (higher four inch pipe) is aligned with the sewer line from the building. (See Fig. 1.3)

BACKFILLING PROCEDURES

Fig. 2.1

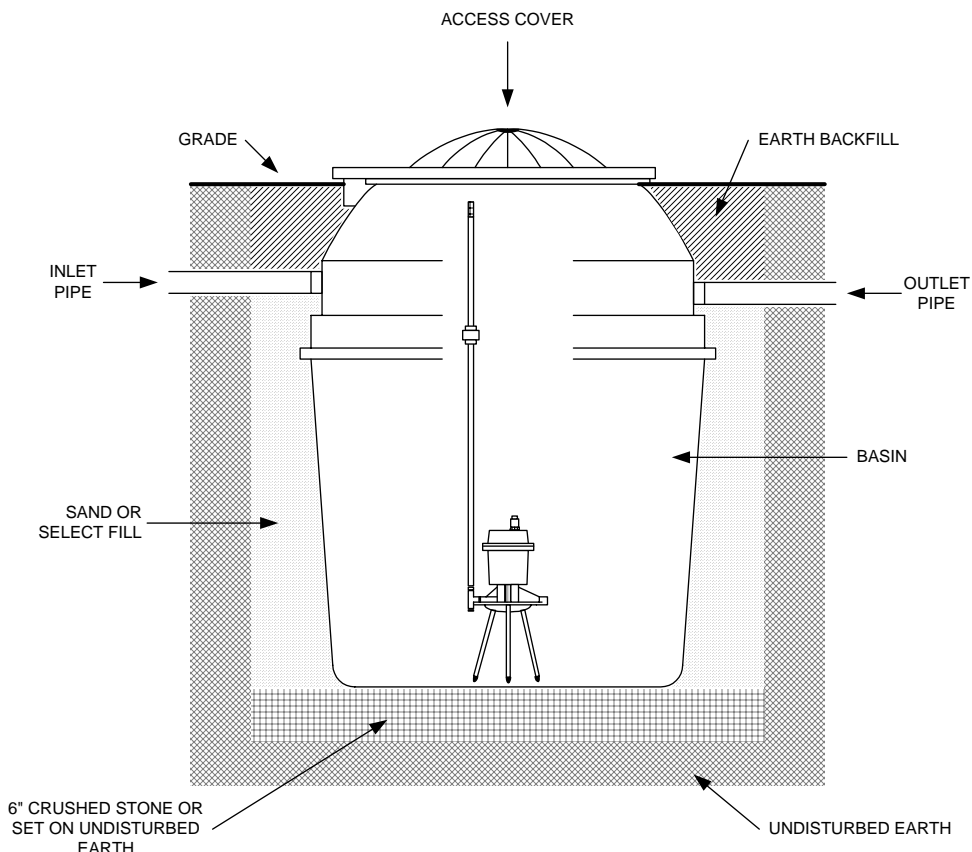

2.20 LEVELING THE WASTEWATER TREATMENT UNIT

CAUTION: The system must be level. A tilted system will not work.

2.21 Place a level across the center tower in several directions. Adjust the tank until it is level. Leveling can be accomplished by shifting the bedding materials. Bedding materials must be evenly distributed to support the weight of the filled tank. **DO NOT USE WEDGES OR OTHER DEVICES TO LEVEL THE TANK.**

2.22 An alternative to using a mechanical level is to plug the outlet pipe with a four inch plastic pipe cap. Fill the area outside of the circular weir with water. As noted in 2.21, adjust the unit until it is perfectly level.

2.30 FILLING THE TANK WITH WATER

CAUTION: To avoid damage from floatation always fill the tank.

2.31 Fill the tank with clean water. Do not fill with water from a pond, river or ground water in the excavation because this water will contain silt or sediment.

2.32 While filling, check frequently to make certain that the tank remains level. If the tank shifts or seems to settle unevenly, discontinue filling and make the necessary corrections to level the tank.

2.33 When the water begins to flow over the weir, stop filling the tank.

2.40 BACKFILLING THE TANK (Fig. 2.1)

2.41 Once the tank has been leveled and has been filled with at least two (2) feet of water, backfilling can begin.

2.42 Using sand, pea gravel or other selected fine material carefully begin backfilling (by hand) until there is approximately 2-3' of compacted fill around the tank.

2.43 After checking the tank to insure it is level, place the access lid on the tank and carefully backfill to the bottom of the outlet pipe. Care should be taken with the backfilling procedures to prevent damaging the tank with rocks or clods of dirt, especially if the original soil is used for backfilling.

2.44 Glue and firmly insert the inlet and outlet sewer pipes (4" Sch. 40 PVC) into their respective fittings. **CAUTION: To prevent any damage to the inlet or outlet pipes due to settling or backfilling, make sure that both the inlet and outlet pipes are set on undisturbed or firmly packed fill material prior to final backfilling.**

2.45 Finish backfilling to a level approximately 2 inches below the access lid. When landscaping is completed, the access lid should be at, or above, finished grade level.

2.46 If the final elevation of the **MULTI-FLO** is below grade so that surface water can enter the access opening of the plant, (1) a dosing pump can be installed prior to the **MULTI-FLO**; or (2) a riser (not exceeding 20") can be provided on the **MULTI-FLO**. **CAUTION: The addition of a riser will make access for service more difficult.**

2.50 INSTALLATION OF FILTER BAGS AND EXPANDERS

2.51 Carefully place an expander into the bag and slide it to the bottom. Be careful not to rip or tear the bag. Even the smallest opening will cause the unit to malfunction.

2.52 Insert the closed end of the filter bag into one of the holes in the hanger plate.

2.53 Continue this process until all filters and expanders are installed. All holes in the hanger plate must have a filter and an expander.

2.60 INSTALLATION OF SPRING FASTENERS

2.61 All filters and expanders must be installed.

2.62 Grasp the spring fastener. (See Fig. 2.2)

2.63 Squeeze the arms of the fastener together until it will slip into the filter bag up to the grooves. (See Fig. 2.3)

2.64 Release the spring, so that the top of the groove in the fastener is on top of the ring that is inside the filter. The bottom of the groove should be in contact with the underside of the hanger plate. The fastener is now holding the filter to the hanger plate. (See Fig. 2.4)

2.65 Place a second spring fastener in the filter at a right angle, so that it lies across the first fastener.

2.66 Continue until each filter has two fasteners in place.

SPRING FASTENERS INSTALLATION

Fig. 2.2



Fig. 2.3



Fig. 2.4



2.70 AERATOR ASSEMBLY AND INSTALLATION

- 2.71 Remove all parts of the aerator from the box. This should include: aerator, legs (3), tee, 1/2" plug, 1/2" nipple, and the owner's manual.
- 2.72 Screw the three (3) legs into the angular threaded holes in the bottom of the aerator cross-shaped piece. Make sure the leg is screwed all the way into the cross.
- 2.73 A plastic cap should be on the plain end of each leg.
- 2.74 Turn the aerator on its side and spin the impeller by hand several times. **THIS STEP IS IMPORTANT.**
- 2.75 With the aerator in the position shown (See Fig. 2.5) assemble the plastic tee to the nipple on the aerator.
- 2.76 Screw the one-half inch plug into the bottom of the tee.
- 2.77 Screw the threaded end of the air intake pipe into the top of the tee.

AERATOR ASSEMBLY

Fig. 2.5

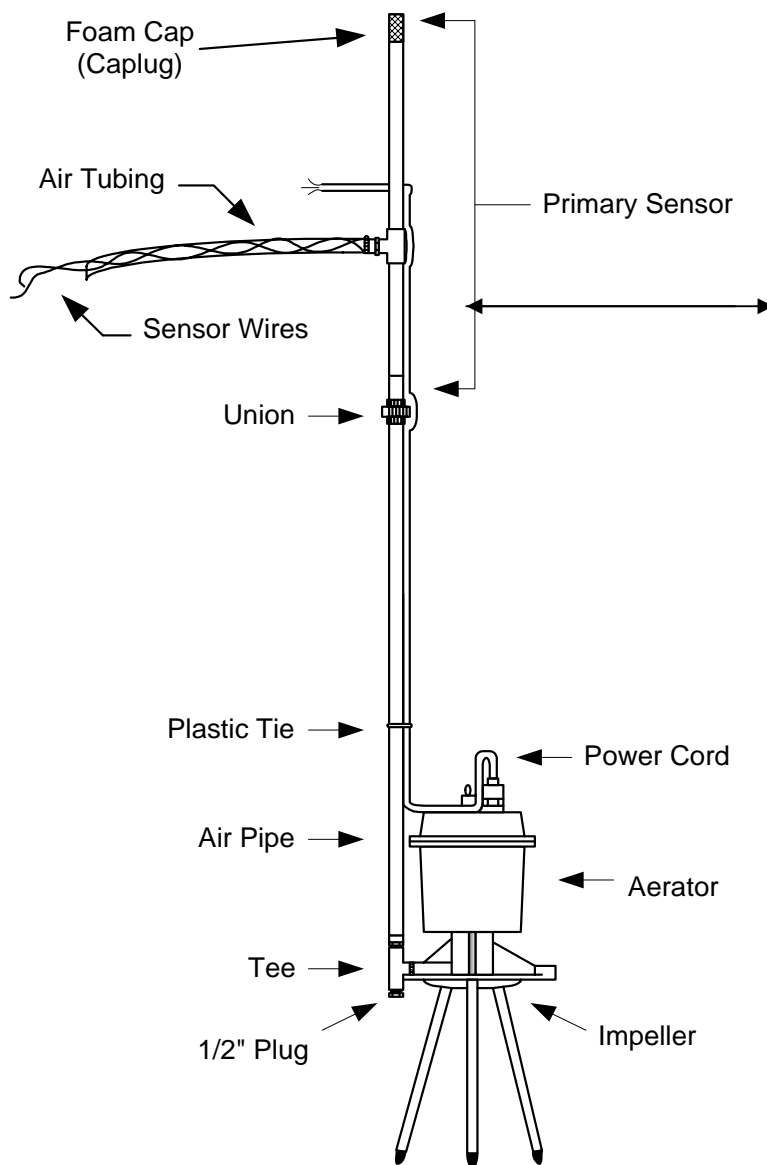

- 2.78 Attach the sensor assembly (Fig. 2.6) with the union to the air intake pipe. Tighten as much as possible by hand. **NOTE:** Be sure that the O ring seal is in the union half of the assembly.
- 2.79 Tie the aerator power cord to the air intake pipe with the plastic ties. **CAUTION: Do not pull or stretch the power cord. To facilitate removal, a nylon rope or chain can be attached to the lifting ring on the top of the aerator.**
- 2.80 By grasping the air intake pipe, carefully lower the aerator assembly through the center of the tank opening to the bottom. **CAUTION: Be sure to keep the air tubing from crimping which will prevent air flow.**

SENSOR ASSEMBLY

Fig. 2.6

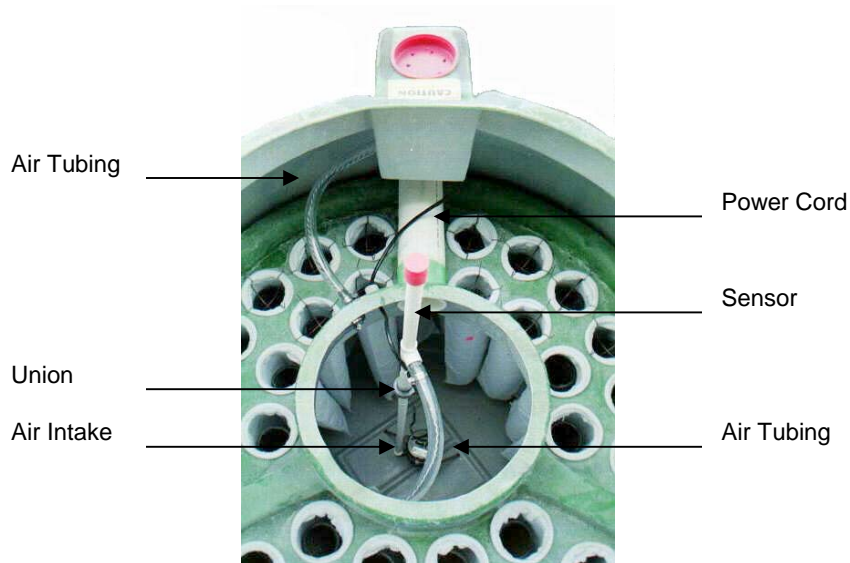

- 2.81 Run the aerator power cord through the fittings as shown in figure 2.6 and into the junction box. **CAUTION: Use care when running the power cord through the fittings. Damage to the cord will void the warranty.**

SECTION 3.0 ELECTRICAL CONNECTIONS (ALARM AND AERATOR) (Refer to specific sheet of direction for each model)

SECTION 4.0 START-UP PROCEDURES

4.10 CHECKING THE AERATOR

- 4.11 Once the aerator and alarm have been installed, and all electrical work is completed, power should be supplied to the aerator and alarm.
- 4.12 Check the aerator to insure proper operation. If no air bubbles are observed coming from the aerator, immediately disconnect the power source. Refer to Items 1A, 1B, and 1C of the Trouble-Shooting Checklist for corrective action.

4.20 CHECKING THE FILTERS

4.21 Once the aerator is running, check each filter to see if any air bubbles are escaping under the filter ring. If so, remove the clips, re-adjust the filter and re-install the clips. Some adjustment may be necessary to eliminate the bubbles.

4.30 CHECKING THE ALARM

4.31 With the power being supplied to the aerator and alarm, press the “test” button to activate the alarm. Note: YOU MUST HOLD THE TEST BUTTON DOWN FOR 6-to-7 SECONDS BEFORE THE ALARM ACTIVATES.

4.32 Shut the power off to the aerator and check if the alarm is activated. Again, allow 6-to-7 seconds for the alarm to sound.

4.33 If the alarm is not activated during these tests, refer to Items IIA and IIC of the Trouble-Shooting Checklist for corrective action.

4.34 If the alarm activates after 10-15 minutes of operation, reverse the white and black sensor wires in the alarm.

4.40 UNIT START-UP

4.41 Once the aerator and alarm have been checked and are operational, the unit is ready to receive sewage flows.

4.42 Normally, it is not necessary to add any chemicals or enzymes to facilitate unit start-up. It is helpful, however, to restrict the discharge of excessive amounts of gray water from showers and laundry during the initial 6-to-8 weeks of use.

4.43 If the **MULTI-FLO** system exhibits a gray dishwater appearance in the aeration chamber, or has a noticeable odor, contact the factory or the local authorized representative for the proper procedure to follow to attain normal operation.

SECTION 5.0 USE OF A PRETREATMENT TANK (Fig. 5.1)

MULTI-FLO has been designed and certified to function without the use of pre-treatment tank. However, installation of a pre-treatment tank, if used to address local requirements or to reduce maintenance problems, will not adversely affect unit performance if it is properly sized and installed.

If a pre-treatment tank is installed, the liquid capacity of the pre-tank should be between 50-to-100 percent of the treatment capacity of the **MULTI-FLO**. Slightly larger tanks can be used with the FTB 0.5 and FTB 0.6. Please refer to the **MULTI-FLO** Design Guide for details.

- 5.11 The use of a pre-tank may cause septic odors to escape from the **MULTI-FLO** during periods of heavy usage (i.e., laundry). In these cases, a 4-inch Schedule 40 elbow can be installed on the inlet pipe to the **MULTI-FLO**. A 12-inch piece of pipe should be added to extend below the surface of the water (refer to Fig. 5.1).

MULTI-FLO INLET DEVICE WHEN INSTALLED AFTER A PRE-TANK

Fig. 5.1

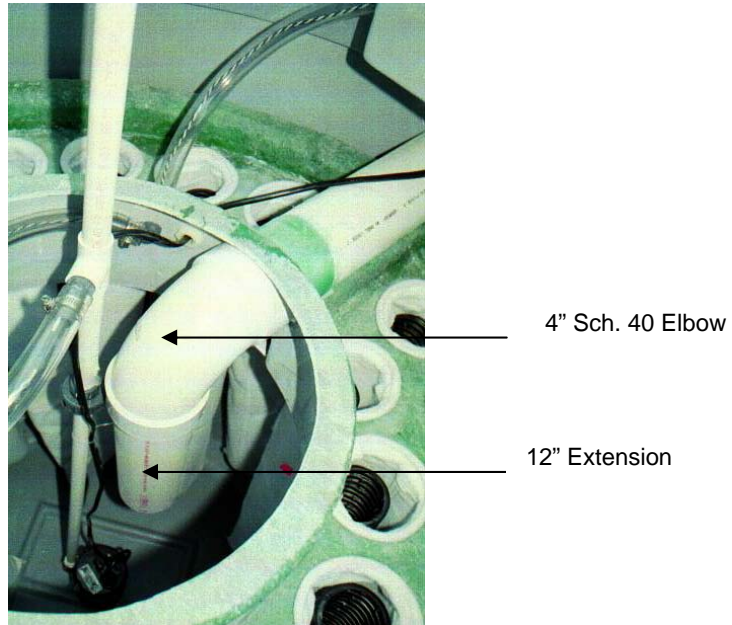

Recommended Multi-Flo Installation Check List for Inspectors

Date:	Installer:
Permit:	Site Address:
Property ID:	Site City and State:

Item			Item		
Administrative Issues			Excavation and Installation	Yes	No
Permit On Site	Yes	No	Level Excavation	Yes	No
Site Protected from Traffic	Yes	No	Bedding Stone Used if rocks present	Yes	No
Benchmark and Baseline	Yes	No	Correct Excavation Elevation	Yes	No
			Level Installation	Yes	No
			Backfill is clean and friable	Yes	No
Electrical Installation			Backfill Compacted	Yes	No
Power Cord Run Through Fitting	Yes	No	Inlet and Outlet Pipes Connected	Yes	No
Watertight Wire Nuts Used	Yes	No	Treatment Tank Filled	Yes	No
Alarm Installed Per Code	Yes	No	Lid 3" Min. Above Grade	Yes	No
Alarm Tested and Functioning	Yes	No	Internal Components	Yes	No
			Aerator Installed and Operating	Yes	No
Final			Filter Media and Expanders Installed	Yes	No
Installation Conforms to Approved Plans	Yes	No	Media Fasteners Installed	Yes	No
			Surge Bowl Installed	Yes	No
			Alarm Installed and Operating	Yes	No
			Lid Installed and Secured	Yes	No

Note: On the backside, make a sketch of the installation noting differences between the plan and actual installation.

Comments and Notes:

The Owner shall be notified in writing about any improper system function that cannot be remedied during the time of inspection and the estimated date of correction.

Additional services (as ordered), replacement of out-of-warranty components, laboratory test work, pumping, will be completed upon written authority from the customer and at an additional charge.

Unless otherwise scheduled, inspections will occur at six-month intervals.

Emergency Services: Emergency services will be conducted within 48 hours of a request.

Owner's Responsibilities: The Owner will receive and should study their Multi-Flo Owner's Manual. This manual details the requirements and restrictions regarding the proper operation of the Multi-Flo wastewater treatment system. This service agreement only covers services covered in connection with the proper operation of the Multi-Flo.

Warranties: This warranty/service agreement does not cover the cost of service calls, labor or materials that result from to "misuse or abuse" of the system; failure to maintain electrical power to the system; sewage flows exceeding the hydraulic /organic design capabilities; disposal of non-biodegradable materials, chemicals, solvents, grease, oil, paint, etc.; or any usage contrary to the requirements listed in the owner's manual or as advised by the authorized maintenance provider.

Specific warranties for equipment and parts are covered under the manufacturers' warranties provided with those equipment and parts. The Maintenance Provider will correct his or her errors and omissions at his or her expense.

Renewal: Within 30 days of the expiration, the Owner will be provided the opportunity to renew this Maintenance Contract. The renewed Maintenance Contract will have a minimum length of one (1) year and include a minimum of two (2) six-month inspections described in the section "Services Provided."

Notifications: The Owner must report evidence of any system failure to the Agent and take appropriate action approved by the agent to correct the problem. Any repair or alteration must comply with OAR 340-071-215, 340-071-0210, and other applicable requirements.

The Maintenance Provider will maintain accurate records of this Maintenance Contract, customer, performance data, and times lines for renewing the contract. These records will be available for inspection upon request by the Agent.

Within 30 days of its termination or expiration of this service agreement, the Maintenance Provider will notify the Agent.

Annually, the Maintenance Provider must submit a report and evaluation fee as required in OAR 340-071-0130 (17)(a) and OAR 340-071-0140(3)(k)(B).

The laws of the State of Oregon govern this contract.

A schedule of fees, charges for parts, and costs for additional services is attached.

Maintenance Provider

Owner

Date

Date

