

Installation Manual

AdvanTex® AX20-RT
Treatment Systems

Residential Applications

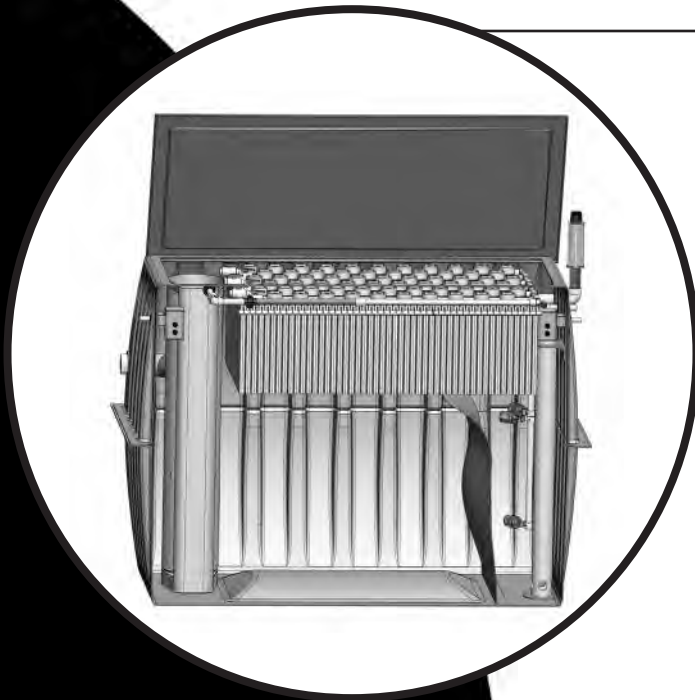

*An illustrated guide to installing
an Orenco AdvanTex® AX20-RT
Treatment System.*



Orenco Systems®
Incorporated

*Changing the Way the
World Does Wastewater®*

800-348-9843
541-459-4449
www.orenco.com
www.vericomm.net

1 Installation Manual: AdvanTex® AX20-RT Treatment Units

Before You Begin Page 1

Overview Page 3

Installation Steps

Step 1: Review or Sketch Site Plans	Page 4
Step 2: Excavate and Set Septic Tank	Page 5
Step 3: Install Risers and Water Test Septic Tank	Page 5
Step 4: Install Effluent Filter	Page 6
Step 5: Excavate and Set AX20-RT Unit	Page 7
Step 6: Determine Antibuoyancy Needs	Page 8
Step 7: Partially Backfill AX20-RT Excavation	Page 9
Step 8: Test Watertightness of AX20-RT Unit	Page 9
Step 9: Connect Transport Line and Passive Air Vent	Page 9
Step 10: Install and Test Control Panel	Page 10
Step 11: Test System Function	Page 13
Step 12: Complete Final Backfill	Page 14

Before You Begin

As the installer of an onsite wastewater treatment system, you play a crucial role. Homeowners, neighbors, service providers, regulators, Dealers, manufacturers ... we all rely on your expertise and good work. At Orenco, we've worked hard to make your installation as easy and "hassle-free" as possible.

We're very proud of this wastewater treatment system. Like all our products, the AdvanTex® AX20-RT Treatment Unit has gone through extensive research, development, and field-testing. Then each component is built to written specifications and subjected to quality review before shipping. In addition, our RTN models meet the requirements of NSF/ANSI Standard 40 for Class I Systems. If this system or any of its components possesses flaws that would inhibit its proper functioning, please contact your authorized AdvanTex Dealer. The Dealer can also provide repair and replacement instructions and replacement components. If there is no authorized AdvanTex Dealer in your area, call Orenco Systems®, Inc. at 800-348-9843 or +1-541-459-4449.



Property owners, neighbors, regulators, Dealers, manufacturers, and service providers all depend on your careful installation.

This manual covers installation of all models of our AdvanTex AX20-RT Treatment Units. In addition to this manual, a separate manual that contains installation, wiring, and operating instructions for Orenco control panels is packaged with the control panel. Please read all other control panel documentation, as well.

It's important that you read through this entire manual before beginning the installation. And make sure you have the correct equipment, materials, tools, and training to perform this installation. Please note that *you must perform the installation according to the current manual to keep the warranty in force.*

Once you become familiar with the installation process, you should be able to install an AdvanTex AX20-RT unit in less than half a day, not counting the time to install the tank and dispersal system.

Conditions for Using an AX20-RT to Repair an Existing System

Before you install an AX20-RT to repair or upgrade an existing septic system, be sure that the following conditions are met:

- The existing septic tank must be Orenco-approved and must meet all applicable regulatory requirements. (No pour-in-place tanks, no homemade tanks, etc.)
- The existing septic tank must be structurally sound.
- The existing septic tank must have at least 1000 gallons (3800 liters) capacity at the normal operating level (1000 gallons or 3800 liters available below the invert of the outlet).
- The existing septic tank must have an at-grade access with a securable and removable lid. If it doesn't, an at-grade access must be installed onto the septic tank and be made watertight.
- The existing septic tank must be tested for leakage to a height of at least 2 inches into the riser, and it must hold water for at least sixty minutes.
- An Orenco effluent filter (model FTS0444-36V, FTW0444-36V, or FT0822-14B) must be installed and accessible in the existing septic tank.
- The depth of burial of the existing septic tank must allow for a fall of at least $\frac{1}{8}$ in. per foot (10 mm per meter or 1%) from the outlet of the septic tank to the inlet of the AX20-RT unit if the septic tank uses a gravity discharge. If sufficient fall cannot be met, a pumping system will need to be installed in the septic tank to move the filtered effluent to the AX20-RT unit. (Contact Orenco for assistance.)

Important Notes

- *All tanks used with AX20-RT Treatment Units must be prequalified. Call your local Dealer for specifics.*
- *The backwash discharge from a salt-type water softener MUST NOT be plumbed into an AX20-RT Treatment Unit or the preceding septic tank. Failure to follow this instruction, or any other in this manual, will void the system's warranty. Contact your AdvanTex Dealer if you have any questions about any household plumbing arrangements that may interfere with the functioning of the system.*
- *All pipe diameters given are U.S. nominal IPS pipe sizes. If you are using metric pipe, you may need adapters to connect to the U.S. fittings supplied.*
- *If you are not a trained AdvanTex Installer, contact your local AdvanTex Dealer or Orenco for training before installing this system.*

3 Installation Manual: AdvanTex® AX20-RT Treatment Units

Overview

The AdvanTex® AX20-RT Treatment System has 10 main functional areas and components:

1. Septic Tank Inlet Tee
2. Biotube® Effluent Filter
3. Biotube Pump Package
4. Recirculating Treatment Tank (recirc side)
5. Manifold and Laterals
6. Textile Media
7. Tank Baffle
8. Recirculating Treatment Tank (discharge side)
9. Flow Inducer and Discharge Pump Assembly (pump discharge only)
10. Control Panel (not shown)

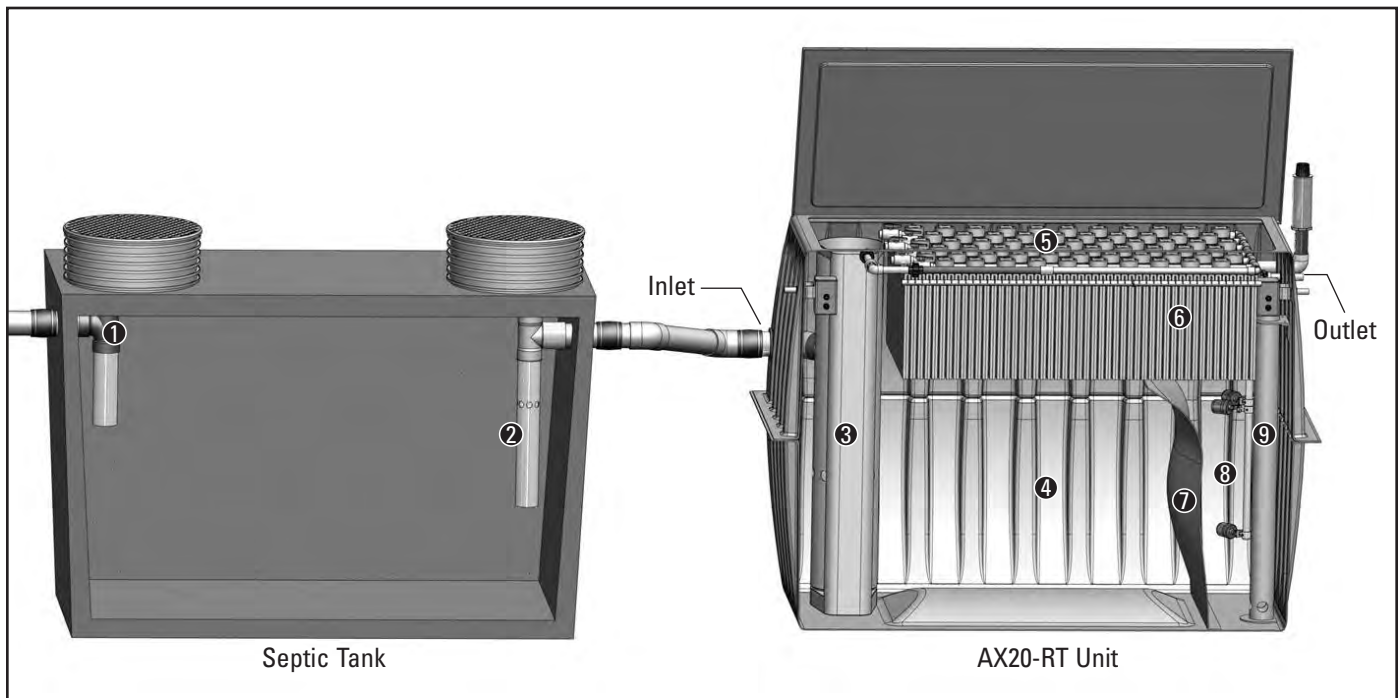

Concrete septic tank and AX20-RT (pump discharge model) shown

Raw sewage enters the septic tank through its inlet tee. In the septic tank, the raw sewage separates into three distinct zones: a scum layer, a sludge layer, and a clear layer. Effluent from the clear layer passes through a Biotube® effluent filter and is discharged by gravity to the recirculating treatment tank portion of the AX20-RT unit, which contains a Biotube Pump Package. The Biotube Pump Package pumps filtered effluent from the recirc side of the AX20-RT unit's recirculating treatment tank to the distribution manifold in the top of the unit. Effluent percolates down through the textile media and is divided — by means of a tank baffle — between the recirculating side and the discharge side of the AX20-RT recirculating treatment tank.

The operation of the pump on the recirc side of the tank baffle is controlled by a timer in the control panel, which allows the pump to dose the textile media for short periods (usually a half-minute or less), typically 72 times a day. This frequent “microdosing,” which optimizes the treatment process, occurs 24 hours a day, to maintain the proper biological environment.

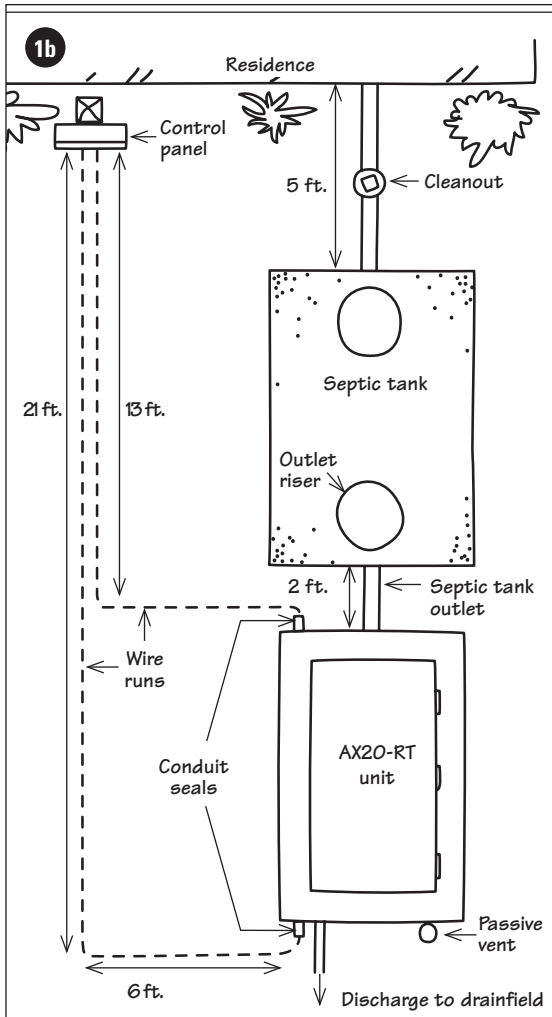

Sample sketch of a possible AX20-RT system layout

Step 1: Review or Sketch Site Plans

Before starting the installation, familiarize yourself with the site plans and specifics of your installation. If you are installing the AX20-RT unit more than 20 feet (6 meters) away from the septic tank, contact your Dealer or Orenco for assistance.

1a) Detailed Site Plans Provided:

If you are installing the AX20-RT according to a set of detailed plans, we recommend that you make sure that your plans accurately reflect conditions at the site. If there are differences between the physical site and the plans, we recommend you contact the Designer before scheduling the installation.

1b) No Site Plans Provided:

If you are installing the AX20-RT without detailed site plans, or with plans of limited detail, contact your local Dealer or Orenco for design assistance.

- Determine and sketch the exact positions of the septic tank and AX20-RT unit on the site. Account for current and likely future landscape features in your sketch.
- Be sure to position the septic tank and unit to allow for a minimum $\frac{1}{8}$ in. per foot (10 mm per meter or 1%) in the line from the outlet of the septic tank to the inlet of the AX20-RT unit, if the septic tank uses a gravity discharge.
- Determine and sketch the layout of your pipes, electrical conduits, and other critical buried elements. Provide measurements and distances on the sketch as accurately as possible.
- Sketch the placement of the control panel. (See Panel Installation, EIN-CP-GEN-1, for installation recommendations.)

Step 2: Excavate and Set Septic Tank

This section covers excavating a hole for the septic tank and setting the septic tank. For information on excavating a hole for the AX20-RT unit, see Step 4.

Consider the necessary elevations and grade requirements for the tank and the AX20-RT unit before excavating the hole for the septic tank. The septic tank must be set at the correct depth to allow for a minimum slope of $\frac{1}{8}$ in. per foot (10 mm per meter or 1%) from the outlet of the septic tank to the inlet of AX20-RT if the septic tank uses a gravity discharge. Also, keep in mind that the AX20-RT needs to sit 2 inches (50 mm) above final grade.

Step 2a: Outline an excavation area (with chalk, paint, string, etc.) for the tank.

Step 2b: Excavate the hole for the septic tank following the tank manufacturer's recommendations. Remember that you need the correct depth for a consistent slope of at least $\frac{1}{8}$ in. per foot (10 mm per meter or 1%) from the septic tank outlet to the inlet of the AX20-RT.

Step 2c: Make sure the bottom of the excavation is free of debris, rocks and other sharp objects. If the bottom of the excavation is uneven or rocky, lay a 4-in. (100-mm) bed of sand or pea gravel and compact the material to create an even, smooth surface.

Step 2d: Set the tank following the manufacturer's instructions. Follow the tank manufacturer's guidelines for watertight testing, antiflotation measures, and backfilling to the level of the top of the tank. Do not backfill past the top of the tank at this time.



Step 3: Install Risers and Water Test Septic Tank

NOTE: This section covers riser installations on septic tanks using gravity discharge. Contact Orenco for riser installations on septic tanks using pump discharge.

Step 3a: Be sure you are installing the right size risers for your application and the size of the tank opening.

Step 3b: Wipe all of the areas to be bonded with a clean rag to ensure a clean, dry bonding surface.

Step 3c: To bond the riser to the riser tank adapter, you can use either ADH100 or methacrylate adhesive alone. However, because ADH100 does not provide a structural joint for approximately 24 hours, we recommend the use of both adhesives. If you use both, apply methacrylate adhesive to the outside surface of the riser tank adapter for a quick (usually an hour or less) structural joint.



Carefully slide the riser onto the adapter.

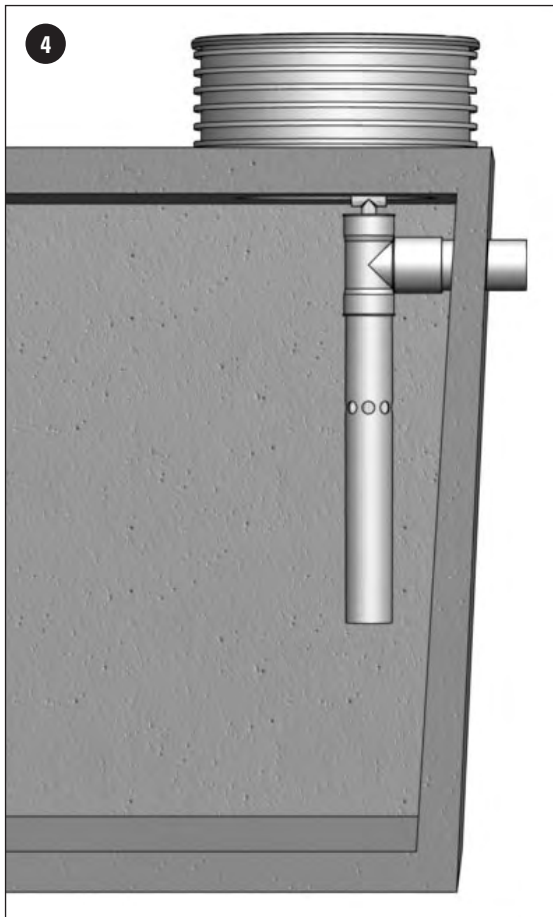

Orenco® effluent filter installed on the septic tank outlet

Step 3d: Carefully slide the riser onto the adapter. Correctly orient the riser before the adhesive starts to set.

Step 3e: Apply a bead of adhesive to the inside of the adapter and riser joint; then use a putty knife or similar tool to form a continuous fillet between the tank adapter and the inside of the riser.

Step 3f: After the adhesives have hardened, fill the tank with clean water to a level 2 in. (50 mm) above the adhesive joint in the riser, to test the watertightness of the tank and the riser joint. Do not allow the water level to rise more than 3 in. (76 mm) into the riser because structural damage to the tank may occur. The septic tank's inlet pipe and outlet pipe need to be turned up or plugged in order for the tank to be filled.

CAUTION: Check the tank manufacturer's guidelines before water testing the tank. Some tank manufacturers require a partial or complete backfill before a tank is water tested.

Step 3g: When the tank proves watertight, drain the excess water to the tank manufacturer's recommended level.

Step 4: Install Effluent Filter

Install the effluent filter after the tank has been water tested.

Step 4a: Verify the model of the effluent filter before you begin to install the filter. Orenco's FTS0444-36V, FTW0444-36V, and FT0822-14B filters are the only models allowed for use with the AX20-RT Treatment Unit.

Step 4b: Test-fit the effluent filter on the septic tank's outlet pipe without gluing. Make sure it fits plumb. Make sure the filter will fit as snug to the tank wall as possible while ensuring sufficient clearance for removing the filter cartridge.

Step 4c: Secure the filter to the outlet pipe. Two attachment methods can be used:

- You can glue the filter onto the tank outlet pipe using appropriate primer and glue.
- You can use a stainless steel set screw to secure the filter.

Step 4d: For easier access when servicing, you can extend the cartridge handle with a longer length of 3/4-in. nominal (20-mm DN) Schedule 40 PVC pipe.

Step 5: Excavate and Set AX20-RT Unit

Before installing the AX20-RT, consider the depth of the septic tank and the height of the septic tank outlet. Remember that there must be a minimum $\frac{1}{8}$ in. per foot slope (10 mm per meter or 1%) from the outlet of the septic tank to the inlet of the AX20-RT, if the septic tank uses a gravity discharge. Also, remember that the AX20-RT lid needs to sit 2 in. (50 mm) above finished grade, to allow for settling and drainage. Take into account any planned landscaping that might affect the finished grade of the system.

Step 5a: Outline an excavation area (with chalk, paint, string, etc.) for the AX20-RT. The excavation needs to extend 18-24 inches (457-610 mm) beyond all four sides of the unit.

Step 5b: Excavate the hole for the unit. The AX20-RT unit height is 72 in. (1830 mm). Make sure that the unit will be set deep enough to facilitate a minimum slope of $\frac{1}{8}$ in. per foot (10 mm per meter or 1%) from the septic tank if the septic tank uses a gravity discharge. Also make sure that the lid will be 2 in. (50 mm) above final grade after the hole for the unit is excavated and after a compacted bed of aggregate or pea gravel — if necessary — is laid.

Step 5c: Make sure the bottom of the excavation is stable and free of debris, especially rocks and other sharp objects.

- If the base soil is unstable (peat, quicksand, muck, soft or highly expansive clay, etc.), overexcavate the site depth and then set a firm, 6-in. (152-mm) compacted base of $\frac{1}{2}$ -in.- to $\frac{3}{4}$ -in.-minus (13- to 19-mm) aggregate or pea gravel. In extremely unstable soil, a concrete layer may be needed to stabilize the bottom of the excavation. If you have any doubt about the soil's ability to support the tank, consult a local civil or structural engineer.
- If the base soil is rocky or uneven, lay a 4-in. (100 mm) bed of sand or pea gravel less than $\frac{3}{8}$ in. (10 mm) in diameter, and compact the material to create an even, smooth surface.

Step 5d: Use properly sized lifting equipment to attach a chain or cable to the two lifting brackets on the top of the AX20-RT unit. Carefully lift the unit and lower it into the excavation. When the unit is set and level in the correct position, remove the chain/cable.

WARNING: Do not allow workers to stand in or near the excavation while placing the unit!

CAUTION: Use a lifting device that will not damage the unit or the lid of the unit.

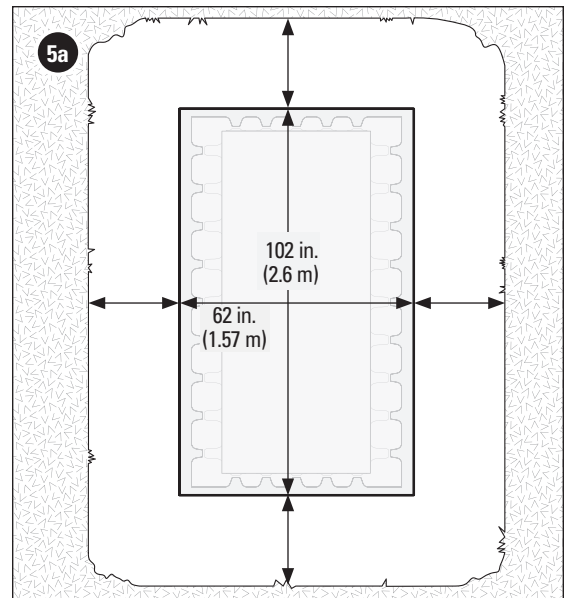

Mark outline of the excavation area 18-24 in. (457-610 mm) beyond all four sides of the unit.

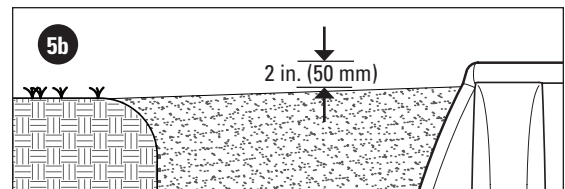

Excavate the hole so that the lid sits at 2 in. (50 mm) above final grade.



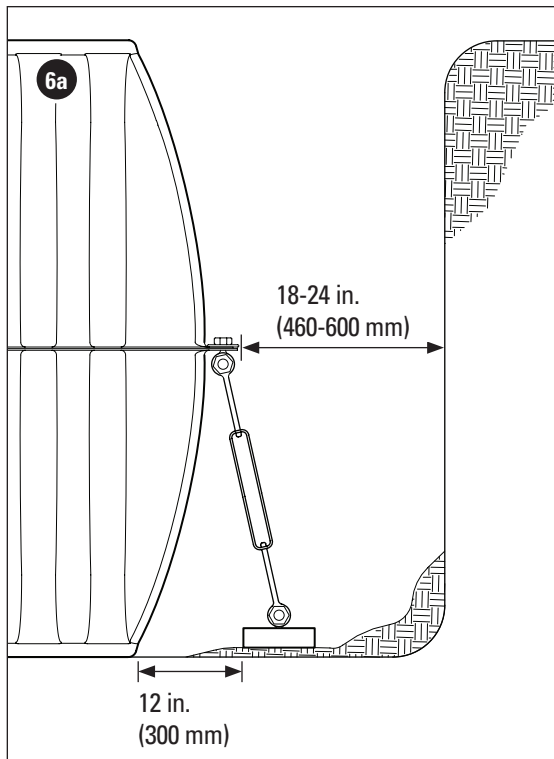

When using Orenco fiberglass deadmen, be sure to place them on a small lift of soil 12 in. (300 mm) from the bottom of the AX20-RT.

Step 6: Determine Antibuoyancy Needs

Because of the AX20-RT's shallow burial depth, you may need to install antibuoyancy deadmen on the unit. Deadmen are necessary when two specific conditions occur at the same time:

- Groundwater is shallower than 36 in. (0.9 m) below grade; and
- The AX20-RT is empty or it is being pumped empty

If these conditions can occur at the site, install Orenco fiberglass deadmen or your own concrete deadmen on the AX20-RT. If you are unsure whether or not your installation requires deadmen, consult the system designer or engineer.

Orenco's counterbuoyancy hardware kits will work with both Orenco fiberglass deadmen and concrete deadmen.

6a) Fiberglass Deadmen

1: Secure the fiberglass deadmen along the length of the unit, on both sides, with the antibuoyancy hardware. Then lower the unit into the excavation.

2: Build up a 3- to 4-in. (75- to 100-mm) lift of soil on each side of the unit for the deadmen to rest upon and place the deadmen at least 12 in. (300 mm) from the bottom of the unit, as shown in illustration 3b.

6b) Concrete Deadmen

1: Forms for concrete deadmen can be made from 12-in diameter × 4-ft long (300-mm × 1200-mm long) PVC half-pipe or chamber material; or simple forms 12 in. wide × 6 in. tall × 4 ft long (300-mm × 150-mm × 1200-mm) can be built from wood.

NOTE: To save time, we recommend preparing concrete deadmen offsite before you install the unit.

2: Fill two forms halfway with concrete, place two #4 reinforcing bars in each of the forms, and then finish filling the forms. When you are finished filling the forms, sink eyebolts from the antibuoyancy hardware kit into the concrete for attaching the deadmen later.

NOTE: Allow the concrete to set completely before lifting or moving the deadmen.

3: Use appropriate lifting gear to set the deadmen in place and secure them along the length of the unit, on both sides, with the antibuoyancy hardware kit.

Step 7: Partially Backfill AX20-RT Excavation

WARNING: DO NOT backfill around the RT unit unless the lid is bolted down! For increased rigidity, keep the AX20-RT lid bolted down while backfilling and compacting.

Step 7a: Fill the AX20-RT unit with 16 in. (410 mm) of water for internal support. Be sure to fill all tank chambers.

Step 7b: Backfill around the unit with a 16-in. (410-mm) layer of material. Native material is acceptable if there are no large or sharp rocks that may damage the unit's walls. If native material is not usable, backfill with ½-in. aggregate or pea gravel. Do not backfill with sand. Use a mechanical compactor to thoroughly compact the fill, to minimize settlement and provide support for the unit's walls.

Step 7c: After completing the first layer of backfill, fill all of the tank chambers with water to just above the midseam flange. Add another 16-in. layer of backfill. Compact the backfill until it is 2-3 in. (50-75 mm) below the midseam flange.

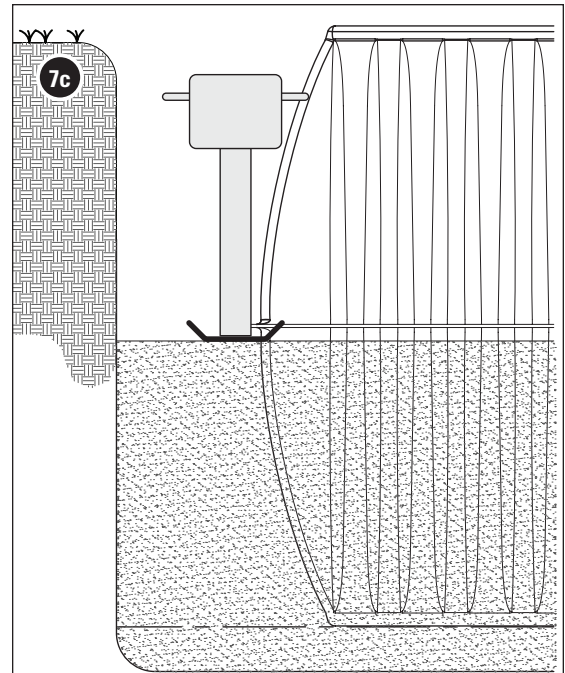

ATTENTION:
Do not backfill around the unit unless the lid is bolted down!

Step 8: Test Watertightness of AX20-RT Unit

Step 8a: After backfilling the AX20-RT excavation to just below the midseam flange, make sure that the unit is filled with water to at least 1 in. (25 mm) above the midseam flange on both sides of the tank baffle.

Step 8b: Wait at least 15 minutes and then inspect the midseam of the unit for leaks. There should be no drop in liquid level and no visible leakage from the seam.



Step 9: Connect Transport Line and Passive Air Vent

NOTE: DO NOT use primer on ABS parts.

Step 9a: Dry fit the 4-in. (100-mm) transport line and any fittings between the outlet of the septic tank and the inlet of the AX20-RT unit. Make sure that you maintain a minimum of ¼ in. per foot (10 mm per meter or 1%) slope from the septic tank if the septic tank uses gravity discharge.

Step 9b: Glue all of the transport line pieces in place.

Step 9c: Use 2-in (50 mm) PVC pipe to plumb the passive air vent to the 2-in. (50 mm) vent fitting that protrudes from the outlet side of the AX20-RT unit. Be sure the vent line is sloped to drain towards the unit and that the passive air vent is within 20 ft (6 m) of the unit. After installation, the top of the passive air vent should be a minimum of 3 in. (75 mm) above final grade.

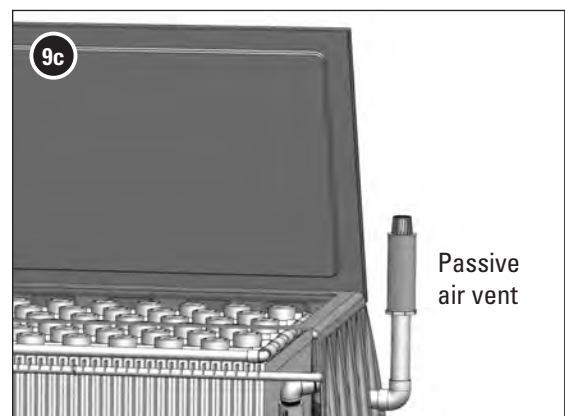



IMPORTANT: In all cases, the line between the passive air vent and the unit must be sloped back $\frac{1}{4}$ in. per foot (20 mm per meter) toward the unit. To prevent accumulation of water, do not allow any “bellies” or low points in the vent piping. Keep the 2-in. vent piping less than 20 ft (6 m) in total length.

Step 9d: We recommend installing the passive air vent near a wall or in a similar location where it is less likely to be damaged by a lawn mower or accidental kicking, etc. You can easily hide the air vent behind shrubbery or other landscaping and paint it if another color is desired.

Step 10: Install and Test Control Panel

Install Control Panel:

For complete control panel installation instructions, see the installation manual for the electrical control panel that comes with your system. Instructions specific to your control panel ship inside of the control panel.*

Step 10a: Make sure the items supplied conform to state and local regulations.

Step 10b: A qualified and licensed electrician should install and service the panel and ancillary wiring in compliance with the National Electrical Code, as well as state and local codes. (Wiring diagrams can be found in the installation manual* that comes with the panel.) Wiring will include the following items:

- Incoming power to the panel. One or more circuits may be required, depending upon the number of pumps and local electrical codes.
- Incoming phone line to the panel (for VeriComm® control panels)
- Wiring from the control panel to the pump and floats
- Wiring to a discharge pump and floats (if applicable)

NOTE: We do not recommend installing a control panel against the wall of a bedroom, living room, or other living space because it makes a periodic thump during operation. If it must be placed near the house, mount it on 4 × 4 (100 × 100 mm) pressure-treated post(s) next to the wall.

Test Control Panel:

VeriComm® (VCOM) telemetry-enabled panels are used for remote monitoring and control of AX20-RT pumping operations.

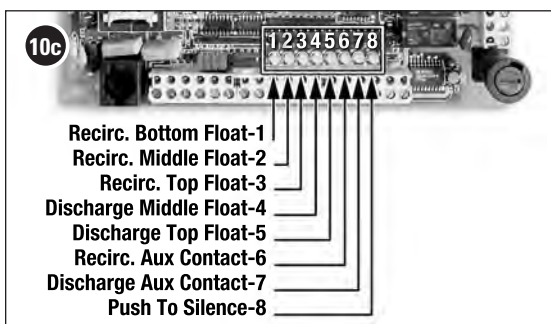
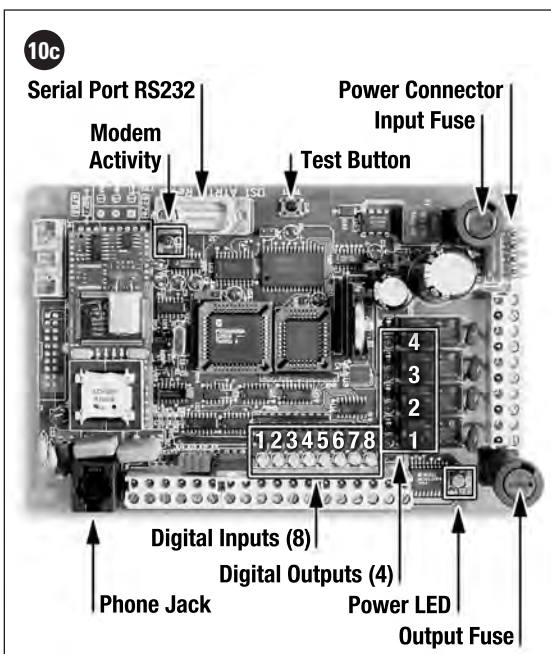

* If the installation instructions are missing from the control panel, find the product model code, located on a sticker inside the panel door. Then call your local Dealer or log in to our online Document Library at www.orenco.com and download a copy of the installation instructions (Category “Instructions, Electrical”). You can also call Orenco for a replacement.

Step 10: Install and Test Control Panel (cont.)

Fault conditions are automatically reported to the VeriComm Monitoring System, making the system virtually invisible to the homeowner. However, if fault conditions are not responded to, or if the system cannot communicate with the VeriComm Monitoring System, then local alarms may be activated.

Perform the following procedures to verify proper installation of the VeriComm panel.

NOTE: For more detailed procedures specific to each panel model, refer to the documentation that comes with the panel.*

Step 10c: Familiarize yourself with the components of the telemetry control board. Step 10d: Make sure the panel has been completely and correctly installed, and verify that the circuit breakers are in the “On” position. Also check the controller status. The power LED, located on the control board, will be:

- *Blinking, which indicates the controller is operating normally, or*
- *Off (when power is applied), which indicates a possible problem with*
 - ~ *the input fuse on the PC board;*
 - ~ *the main fuse located inside the panel;*
 - ~ *the controls circuit breaker located inside the panel; or*
 - ~ *the incoming line voltage.*

Step 10e: To enable Test Mode, hold the “Push-To-Silence” button on the front of the panel until the audible alarm sounds (approximately 15 seconds).

- *The appropriate digital input should be illuminated when the button is held in.*
- *When the audible alarm sounds to indicate that the panel is in Test Mode, release the button.*

While in Test Mode, the panel will operate in the following manner:

- *The call-in function is disabled;*
- *Local audible and visual alarms are activated as alarm conditions occur;*
- *System Data Logs are suspended; and*
- *Timer cycles are shortened.*

Step 10f: Familiarize yourself with the floats on the system.

Step 10g: Verify that the pump is submerged in water before continuing. If the bottom float drops, the alarm should sound. Press down the spring-loaded “AUTO/OFF/MAN” switch located inside the panel. The pump should immediately activate. For verification, the appropriate digital input should illuminate, indicating that the auxiliary contact is on.

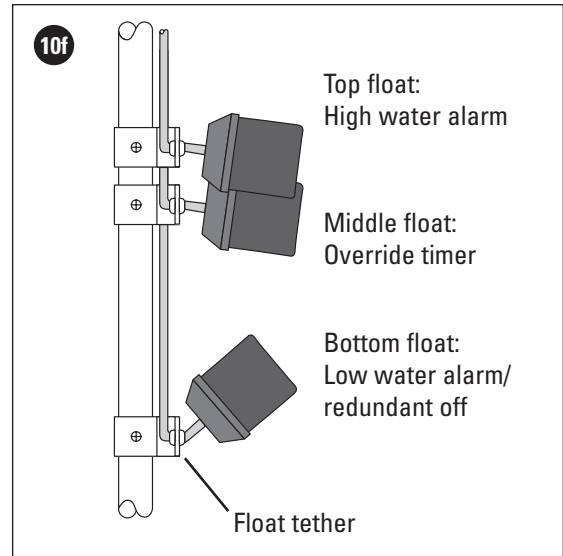

VeriComm® Recirculating Float Assembly shown



Measure voltage



Measure amperage

Step 10: Install and Test Control Panel (cont.)

Measure the voltage and amperage of the pump.

- a) Measure the voltage at the pump terminals in the panel. Measuring the voltage with the pump off will confirm that the correct voltage is connected. Then activate the pump by toggling the AUTO/OFF/MAN switch to MAN, or using a PDA or laptop with the Bluetooth Device, and measure the voltage while the pump is running. The maximum recommended voltage drop is 3%. A low voltage condition may indicate that the site wiring is improperly sized.
- b) Using a loop ammeter, place the ammeter clamp around the loop of wire located above the pump circuit breaker and read the amperage while the pump is running and connected to the discharge assembly with the valves at the end of the laterals closed. The amperage should be within the specifications of the pump.

Step 10h: Refer to the control panel documentation to test the floats that activate/deactivate the pump. To perform the float test, make sure there is enough liquid in the tank. If there isn't enough liquid in the tank, turn the pump circuit breaker off.

NOTE: If phone service to the panel is active, complete step 10i. If not, proceed to step 10j. However, phone service should be activated before system start-up.

Step 10i: Press and release the “Push-To-Silence” button 15 times within a one-minute period. This instructs the panel to call the VeriComm Monitoring System.

- A red LED (“Modem Activity” component) should illuminate, indicating that the controller has established communication with the host. (This may take a few minutes.)
- Once the communication session has ended, the modem will automatically disconnect.
- If the LED does not illuminate within the specified time, verify that the phone line has a dial tone. This can be done by hooking up a phone to the line that is going into the panel.

Step 10j: The panel will automatically disable Test Mode and return to normal operation after 30 minutes. To disable Test Mode manually, hold the “Push-To-Silence” button on the front of the panel until the audible alarm sounds (approximately 15 seconds). The appropriate digital input should be illuminated when the “Push-To-Silence” button is held in. When the audible alarm sounds to indicate that the panel is no longer in Test Mode, release the button.

Step 11: Test System Function

Once power is connected to the control panel, follow these steps to prepare the system for operation.

IMPORTANT: Before using a generator to operate a pump, contact your Dealer or Orenco to make sure the generator can supply sufficient starting amperage.

NOTE: When testing pumps, always make sure there is enough water in the unit to safely run the pumps.

Step 11a: Open the manifold valve and the lateral ball valves and then toggle the “AUTO/OFF/MAN” switch for the recirc pump to “MAN” for 5-10 seconds to flush any debris out of the manifold and laterals. Close the lateral ball valves. With the recirc pump still in “MAN,” remove several orifice shields and measure squirt height. Squirt height should measure between 3-5 ft (0.9-1.5 m). Windy conditions will cause a lower squirt height. When finished, return the “AUTO/OFF/MAN” switch to “AUTO.”

NOTE: If the desired squirt height is not achieved or the unit does not pressurize, check for debris, breaks, or closed valves. Also verify that the pump is receiving sufficient power. If the unit still does not pressurize correctly, contact your Dealer or Orenco for technical assistance.

Step 11b: Place the control panel in Test Mode. Check the function of the recirc pump floats by lifting the low-level, mid-level, and high-level float in turn and verifying that the pump cycles on and off for each. If the unit is not equipped with a discharge pump, take the control panel out of Test Mode at this time.

Step 11c: If the unit has a discharge pump, make sure there is enough water on the discharge side of the tank baffle for the pump to run. Make sure the control panel is in Test Mode. Check the function of the discharge pump floats by lifting the low-level, mid-level, and high-level float in turn and verifying that the pump cycles on and off for each. When you are finished, take the control panel out of Test Mode.

Step 11d: Close and bolt down the AX20-RT unit lid when you are finished.

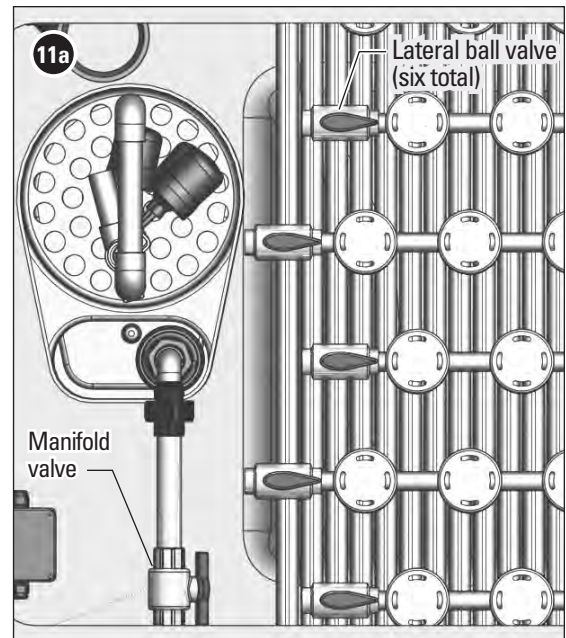

Open the manifold valve and lateral valves.



Measure squirt height.

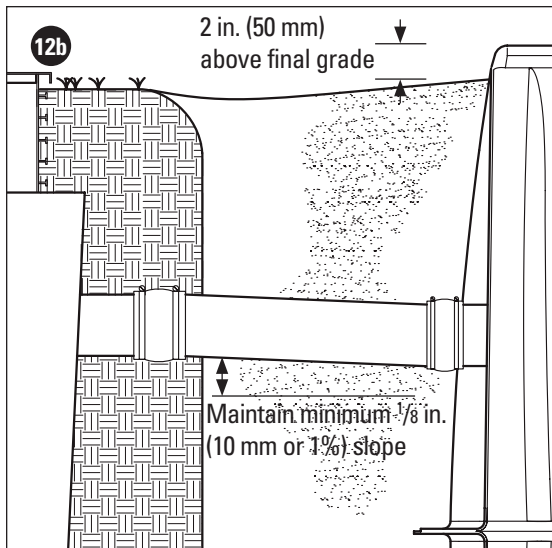

Backfill the AX20-RT in 12-in. (300 mm) lifts

Step 12: Complete Final Backfilling

IMPORTANT: When backfilling, be careful not to alter the slope of pipes. Brace the pipes or place the pipes on a compacted bed and carefully fill around them.

NOTE: Before backfilling, make sure the AX20-RT unit lid and all riser lids are bolted down.

Step 12a: Backfill the septic tank excavation if it has not yet been done. Follow the tank manufacturer's guidelines for backfilling.

Step 12b: Backfill and compact around the AX20-RT unit in maximum 12-in. (305-mm) lifts. Native material is acceptable if there are no large or sharp rocks that may damage the unit's walls. If native material is not usable, backfill with 1/2-in. aggregate or pea gravel. For installations in non-cohesive soils* with high seasonal water tables, use 3/4-in. crushed rock as the backfill material. The top of the AX20-RT lid should sit 2 in. (50 mm) above final grade.

IMPORTANT: After backfilling, call the system's Service Provider to arrange for the official System Start-up.

* As described in OSHA Standards (29 CFR, Part 1926, Subpart P, Appendix A), noncohesive soils or granular soils include gravel, sand, or silt with little or no clay content. Granular soil cannot be molded when moist and crumbles easily when dry. Cohesive soils include clayey silt, sandy clay, silty clay, clay, and organic clay. Cohesive soil does not crumble, can be excavated with vertical sideslopes, is hard to break up when dry, and when moist, can be rolled into threads without crumbling. For example, if at least a 2-in. (51-mm) length of 1/8-in. (3-mm) thread can be held on one end without tearing, the soil is cohesive.

**AdvanTex® AX20-RT
Treatment Systems**

Installation Manual

Residential Applications



Oreco Systems®
Incorporated

*Changing the Way the
World Does Wastewater®*

**800-348-9843
541-459-4449
www.oreco.com
www.vericomm.net**



AdvanTex Treatment System RTN Models meet the requirements of NSF/ANSI Standard 40 for Class I Systems.



**NIM-ATX-AXRT-1
Rev. 1.2, © 11/10
Oreco Systems®, Inc.**